

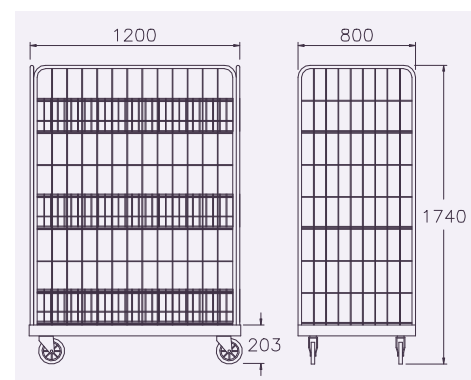

BANDEJA CARRO EXPOSITOR

SHELF BALCONY DISPLAY TROLLEY

BCE



CODIFICACION BASICA CARROS DE TRANSPORTE

TRANSPORT TROLLEY CODE



108 160 Ø

**CEX108**

75,5 kg.

4 GIRATORIAS DE 160 Ø

160 Ø 4 SWIVEL WHEELS



CODIFICACION BASICA CARROS DE TRANSPORTE

TRANSPORT TROLLEY CODE

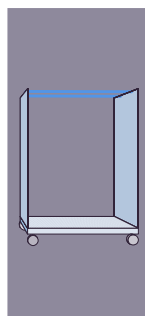
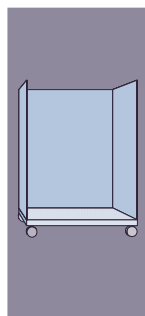
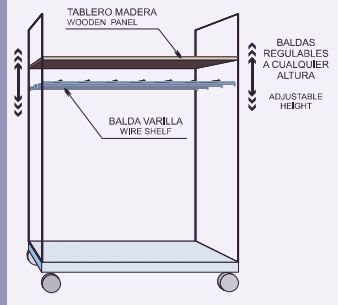

|      |  |                              |                              |
|------|--|------------------------------|------------------------------|
| 1480 | 2 GIRATORIAS<br>2 FIJAS<br>2 SWIVEL WHEELS<br>2 FIXED WHEELS | <b>CME102-3</b><br>72,0 kg.  | <b>CME104-5</b><br>72,6 kg.  |
|      | 4 GIRATORIAS<br>4 SWIVEL WHEELS                              | <b>CME102</b><br>73,0 kg.    | <b>CME104</b><br>73,7 kg.    |
| 1750 | 2 GIRATORIAS<br>2 FIJAS<br>2 SWIVEL WHEELS<br>2 FIXED WHEELS | <b>CMEG102-3</b><br>76,6 kg. | <b>CMEG104-5</b><br>77,2 kg. |
|      | 4 GIRATORIAS<br>4 SWIVEL WHEELS                              | <b>CMEG102</b><br>77,6 kg.   | <b>CMEG104</b><br>78,3 kg.   |

- TABLERO MADERA  
WOODEN PANEL
- TMCM12060**
- BALDA DE VARILLA  
WIRE SHELF
- BCMV12060**

|      |  |                                |                                |
|------|--|--------------------------------|--------------------------------|
| 1480 | 2 GIRATORIAS<br>2 FIJAS<br>2 SWIVEL WHEELS<br>2 FIXED WHEELS | <b>CMESR102-3</b><br>33,0 kg.  | <b>CMESR104-5</b><br>33,6 kg.  |
|      | 4 GIRATORIAS<br>4 SWIVEL WHEELS                              | <b>CMESR102</b><br>34,0 kg.    | <b>CMESR104</b><br>34,7 kg.    |
| 1750 | 2 GIRATORIAS<br>2 FIJAS<br>2 SWIVEL WHEELS<br>2 FIXED WHEELS | <b>CMESRG102-3</b><br>37,6 kg. | <b>CMESRG104-5</b><br>38,2 kg. |
|      | 4 GIRATORIAS<br>4 SWIVEL WHEELS                              | <b>CMESRG102</b><br>38,6 kg.   | <b>CMESRG104</b><br>39,3 kg.   |

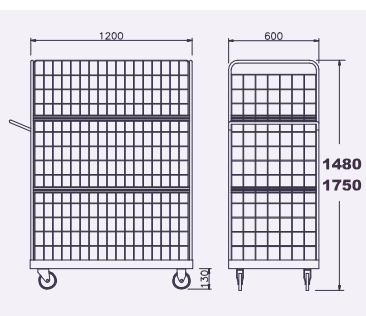



CARRO MERCANCIAS SEGURIDAD

SECURITY TROLLEY



PUERTAS ABATIBLES A 270° EQUIPADAS CON CERROJO, SEGURIDAD PARA EL ALMACENAJE, DISTRIBUCION O EXPOSICION DE SUS PRODUCTOS.

270° FOLDING DOORS INCLUDING BOLT FOR SECURITY DURING STOCKING, TRANSPORTING AND DISPLAYING PRODUCTS.

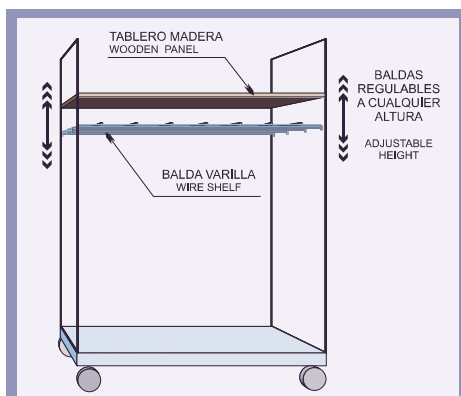

TABLERO MADERA  
WOODEN PANEL  
TMCM12060

BALDA DE VARILLA  
WIRE SHELF  
BCMV12060

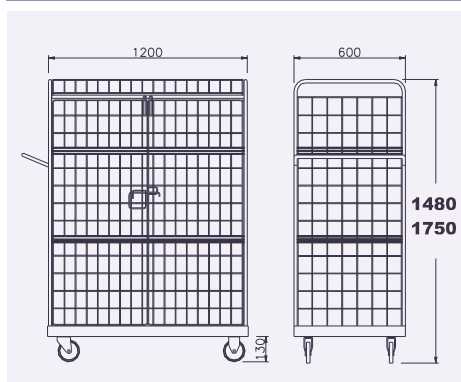

CODIFICACION BASICA CARROS DE TRANSPORTE

TRANSPORT TROLLEY CODE



|      |  |                              |                               |
|------|--|------------------------------|-------------------------------|
| 1480 | 2 GIRATORIAS<br>2 FIJAS<br>2 SWIVEL WHEELS<br>2 FIXED WHEELS | <b>CMES102-3</b><br>85,0 kg. | <b>CMES104-5</b><br>85,6 kg.  |
|      | 4 GIRATORIAS<br>4 SWIVEL WHEELS                              | <b>CMES102</b><br>86,0 kg.   | <b>CMES104</b><br>86,7 kg.    |
| 1750 | 2 GIRATORIAS<br>2 FIJAS<br>2 SWIVEL WHEELS<br>2 FIXED WHEELS | <b>CMESG102-3</b><br>89,6kg. | <b>CMESG104-5</b><br>90,2 kg. |
|      | 4 GIRATORIAS<br>4 SWIVEL WHEELS                              | <b>CMESG102</b><br>90,6 kg.  | <b>CMESG104</b><br>91,3 kg.   |



REJILLA TRASERA 700  
700 REAR GRILL  
RTRT700

REJILLA TRASERA 660  
660 REAR GRILL  
RTRT660

BANDEJA 800 x 700  
800 x 700 SHELF  
BRT8070

BANDEJA 800 x 660  
800 x 660 SHELF  
BRT8066

SENSOR DE GOMA  
RUBBER STRAP  
TGRR

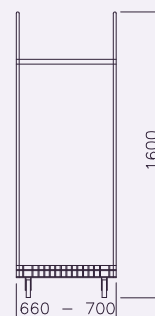
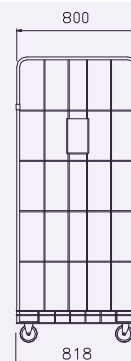

CODIFICACION BASICA ROLL-TAINER

ROLL-TAINER CODES



|                 |  |                               |                               |                               |                               |
|-----------------|--|-------------------------------|-------------------------------|-------------------------------|-------------------------------|
| 800<br>x<br>700 | 2 GIRATORIAS<br>2 FIJAS<br>2 SWIVEL WHEELS<br>2 FIXED WHEELS | <b>RT87/116-7</b><br>30,6 kg. | <b>RT87/118-9</b><br>31,0 kg. | <b>RT87/102-3</b><br>30,5 kg. | <b>RT87/104-5</b><br>31,1 kg. |
|                 | 4 GIRATORIAS<br>4 SWIVEL WHEELS                              | <b>RT87/116</b><br>30,6 kg.   | <b>RT87/118</b><br>31,0 kg.   | <b>RT87/102</b><br>30,5 kg.   | <b>RT87/104</b><br>31,2 kg.   |
| 800<br>x<br>660 | 2 GIRATORIAS<br>2 FIJAS<br>2 SWIVEL WHEELS<br>2 FIXED WHEELS | <b>RT86/116-7</b><br>29,6 kg. | <b>RT86/118-9</b><br>30,0 kg. | <b>RT86/102-3</b><br>29,5 kg. | <b>RT86/104-5</b><br>30,1 kg. |
|                 | 4 GIRATORIAS<br>4 SWIVEL WHEELS                              | <b>RT86/116</b><br>29,6 kg.   | <b>RT86/118</b><br>30,0 kg.   | <b>RT86/102</b><br>29,5 kg.   | <b>RT86/104</b><br>30,2 kg.   |





VERSION AMPLIADA SOBRE EL ROLL-TAINER QUE MEDIANTE DIFERENTES COMBINACIONES ADMITE MULTITUD DE APLICACIONES EN SU USO.

THE EXTENDED VERSION OF THE ROLL TAINER WITH MULTIPLE FUNCTIONS AND WIDE RANGE OF COMPONENT COMBINATIONS.



LAS POSIBILIDADES DE COMBINACION DE TODOS SUS COMPONENTES CONVIERTEN A ESTE ROLL TAINER EN UN COMPLEMENTO IDEAL PARA CUALQUIER ALMACEN.

THE CONCEPT OF THIS PRODUCT IS THE BEST COMPLEMENT FOR ANY WAREHOUSE.



SU GRAN VERSATILIDAD PERMITE CUBRIR LAS NECESIDADES DE TODO TIPO DE NEGOCIOS.

VERSATILITY BRINGS YOU THE POSSIBILITY TO ADAPT TO ALL KIND OF BUSSINESS

COMPONENTES PARA MULTI-ROLL  
MULTI-ROLL COMPONENTS

DEBIDO A SU CONCEPTO DE PRODUCTO LOS COMPONENTES MULTI-ROLL COMPONENTS ARE NOT CONSIDERED AS  
PARA EL MULTI-ROLL NO SON CONSIDERADOS ACCESORIOS. ACCESSORY, ASK FOR ANY REQUIREMENT.  
PARA CUALQUIER COMPOSICION, CONSULTAR PREVIAMENTE.

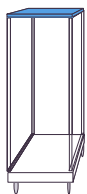

TECHO SUPERIOR GRANDE **700**  
**700 TOP COVER**  
**TSGRT700**

TECHO SUPERIOR GRANDE **660**  
**660 TOP COVER**  
**TSGRT660**

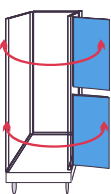

DOBLE PUERTA ABATIBLE **700**  
**700 DOUBLE FOLDING DOOR**  
**DPART700**

DOBLE PUERTA ABATIBLE **660**  
**660 DOUBLE FOLDING DOOR**  
**DPART660**



BANDEJA EXTENSIBLE **700**  
**700 EXTRACTABLE BASE**  
**BCGERT700**

BANDEJA EXTENSIBLE **660**  
**660 EXTRACTABLE BASE**  
**BCGERT660**



TECHO SUPERIOR PEQUEÑO **700**  
**700 SMALL TOP COVER**  
**TSPRT700**

TECHO SUPERIOR PEQUEÑO **660**  
**660 SMALL TOP COVER**  
**TSPRT660**

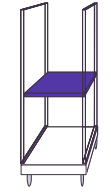

BANDEJA DE CHAPA **700**  
**700 SHEET SHELF**  
**BCRT700**

BANDEJA DE CHAPA **660**  
**660 SHEET SHELF**  
**BCRT660**

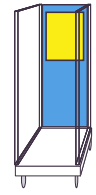

FONDO CHAPA PUBLICIDAD **700**  
**700 SHEET PANEL FOR ADVERTISING**  
**FCRT700**

FONDO CHAPA PUBLICIDAD **660**  
**660 SHEET PANEL FOR ADVERTISING**  
**FCRT660**



BARRA RIOSTRA **700**  
**700 BRACE**  
**BRRT700**

BARRA RIOSTRA **660**  
**660 BRACE**  
**BRRT660**



BANDEJA CHAPA PLATAFORMA **700**  
**700 BOTTOM SHEET SHELF**  
**BCPRT700**

BANDEJA DE CHAPA PLATAFORMA **660**  
**660 BOTTOM SHEET**  
**BCPRT660**

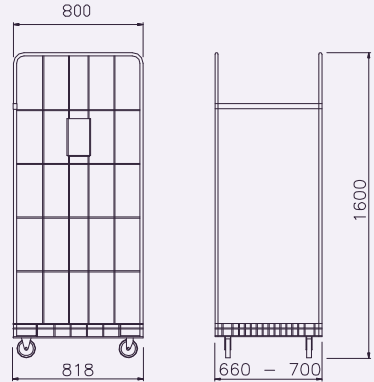



PUERTA ABATIBLE GRANDE **700**  
**700 FOLDING DOOR**  
**PAGRT700**

PUERTA ABATIBLE GRANDE **660**  
**660 FOLDING DOOR**  
**PAGRT660**

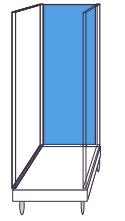

BANDEJA CHAPA ABATIBLE **700**  
**700 FOLDING SHEET SHELF**  
**BCART700**

BANDEJA CHAPA ABATIBLE **660**  
**660 FOLDING SHEET SHELF**  
**BCART660**



REJILLA TRASERA **700**  
**700 REAR GRILL**  
**RTRT700**

REJILLA TRASERA **660**  
**660 REAR GRILL**  
**RTRT660**

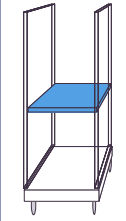

BANDEJA **800 x 700**  
**800 x 700 SHELF**  
**BRT8070**

BANDEJA **800 x 660**  
**800 x 660 SHELF**  
**BRT8066**



TENSOR DE GOMA  
RUBBER STRAP  
**TGRR**

CODIFICACION BASICA ROLL-TAINER

ROLL-TAINER CODE



|                  |  |                               |                               |                               |                               |
|------------------|--|-------------------------------|-------------------------------|-------------------------------|-------------------------------|
| <b>800 x 700</b> | 2 GIRATORIAS<br>2 FIJAS<br>2 SWIVEL WHEELS<br>2 FIXED WHEELS | <b>RT87/116-7</b><br>30,1 kg. | <b>RT87/118-9</b><br>31,0 kg. | <b>RT87/102-3</b><br>30,5 kg. | <b>RT87/104-5</b><br>31,1 kg. |
|                  | 4 GIRATORIAS<br>4 SWIVEL WHEELS                              | <b>RT87/116</b><br>30,6 kg.   | <b>RT87/118</b><br>31,0 kg.   | <b>RT87/102</b><br>30,5 kg.   | <b>RT87/104</b><br>31,2 kg.   |
| <b>800 x 660</b> | 2 GIRATORIAS<br>2 FIJAS<br>2 SWIVEL WHEELS<br>2 FIXED WHEELS | <b>RT86/116-7</b><br>29,6 kg. | <b>RT86/118-9</b><br>30,0 kg. | <b>RT86/102-3</b><br>29,5 kg. | <b>RT86/104-5</b><br>30,1 kg. |
|                  | 4 GIRATORIAS<br>4 SWIVEL WHEELS                              | <b>RT86/116</b><br>29,6 kg.   | <b>RT86/118</b><br>30,0 kg.   | <b>RT86/102</b><br>29,5 kg.   | <b>RT86/104</b><br>30,2 kg.   |



DOBLE PUERTA  
DOUBLE DOOR



PUERTA SUPERIOR ABATIBLE  
UPPER FOLDING DOOR



PUERTA SIMPLE GRANDE  
SIMPLE DOOR





DISEÑO ESPECIFICO Y FUNCIONAL PARA EL SECTOR DE LAVANDERIA INDUSTRIAL  
PERFECT DESIGN CONVENIENCE FOR THE LAUNDRY INDUSTRIES

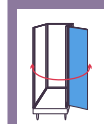
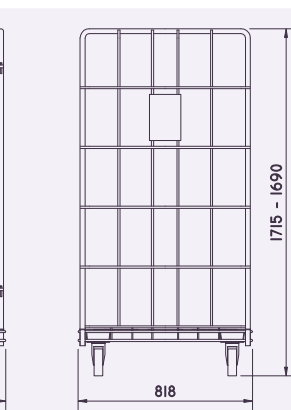
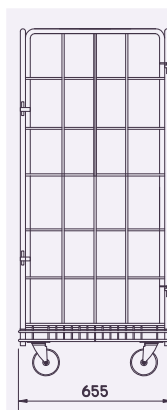
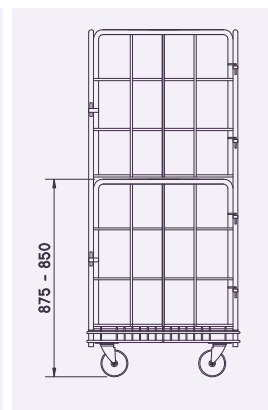
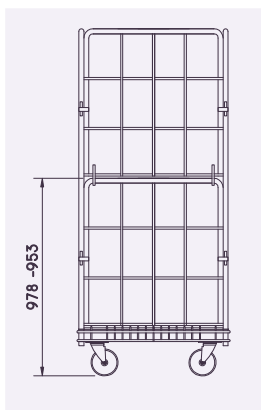

2 GIRATORIAS  
2 FIJAS  
2 SWIVEL WHEELS  
2 FIXED WHEELS  
4 GIRATORIAS  
4 SWIVEL WHEELS

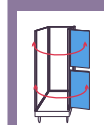

2 GIRATORIAS  
2 FIJAS  
2 SWIVEL WHEELS  
2 FIXED WHEELS  
4 GIRATORIAS  
4 SWIVEL WHEELS

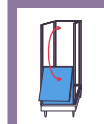

2 GIRATORIAS  
2 FIJAS  
2 SWIVEL WHEELS  
2 FIXED WHEELS  
4 GIRATORIAS  
4 SWIVEL WHEELS

CODIFICACION BASICA ROLL-TAINER

ROLL-TAINER CODE



**RLPSG86/118-9**  
37,0 kg.

**RLPSG86/104-5**  
37,1 kg.

**RLPSG86/118**  
37,0 kg.

**RLPSG86/104**  
37,2 kg.

**RLDP86/118-9**  
37,0 kg.

**RLDP86/104-5**  
37,1 kg.

**RLDP86/118**  
37,0 kg.

**RLDP86/104**  
37,2 kg.

**RLPSA86/118-9**  
37,0 kg.

**RLPSA86/104-5**  
37,1 kg.

**RLPSA86/118**  
37,0 kg.

**RLPSA86/104**  
37,2 kg.



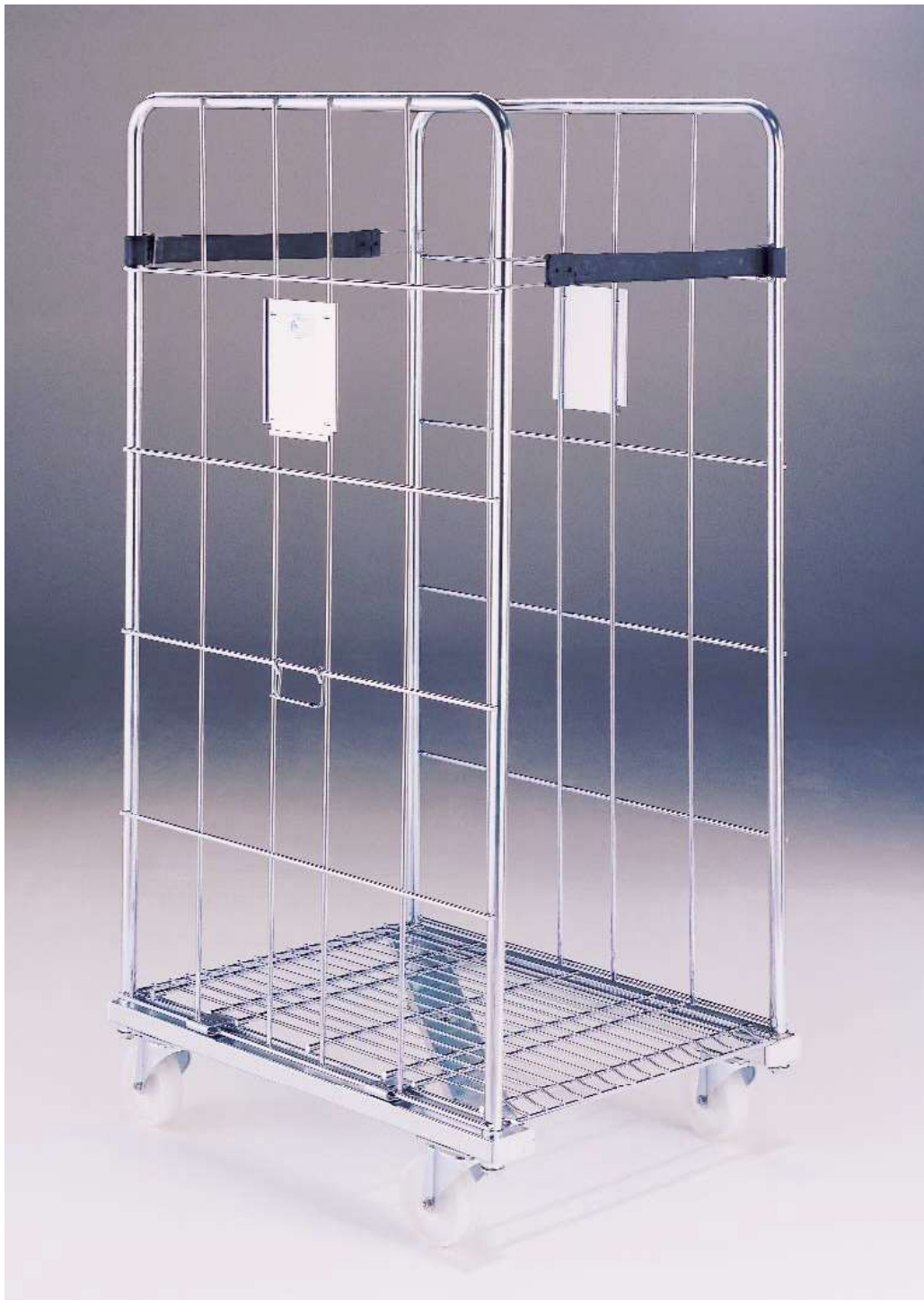

REJILLA DE BASE ABATIBLE CON ABRAZADERA DE SUJECCION INCORPORADA, PERMITIENDO LA PERFECTA ENCAJABILIDAD EN LINEA

FOLDING BASE PLATFORM WITH FASTENING BRACKET WHICH ALLOWS THE PERFECT NESTING IN LINE.

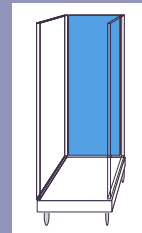

REJILLA TRASERA 700  
700 REAR PANEL  
RTRT700

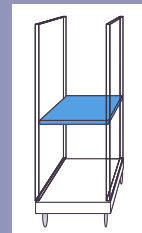

BANDEJA 800 x 700  
800 x 700 SHELF  
BRT8070

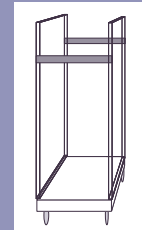

TENSOR DE GOMA  
RUBBER TENSIBLE  
TGRR

CODIFICACION BASICA ROLL-TAINER

ROLL-TAINER CODE



104 125 Ø

REZ104  
33,0 kg.

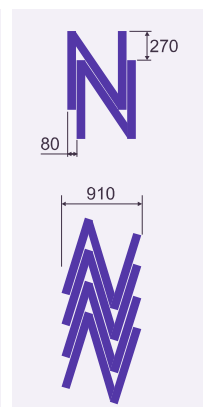
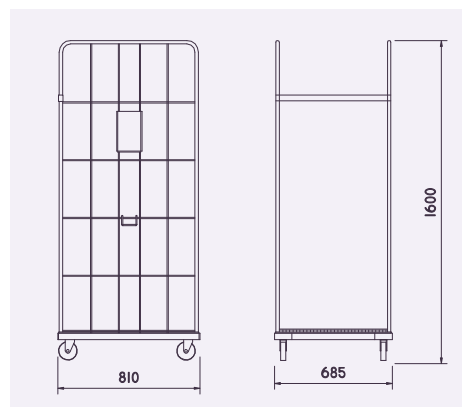



BANDEJAS MOVILES DE FACIL ACCESO QUE PERMITEN TRABAJAR EN CONDICIONES EXTREMAS DE HUMEDAD Y FRIO POR SU ESPECIAL ACABADO.

EASY-ACCESS MOVABLE TRAYS FOR EXTREME COLD AND HUMIDITY CONDITIONS DUE TO THEIR SPECIAL FINISHING.

POR SU CONFIGURACION PERMITE UNA EXCELENTE DISTRIBUCION, CLASIFICACION Y PREPARACION DE PRODUCTO.

DESIGNED FOR PERFECT PRODUCT HANDLING, DISTRIBUTION AND SORTING



CODIFICACION BASICA ROLL-TAINER

ROLL-TAINER CODE



104

125 Ø



105

125 Ø

2 GIRATORIAS  
2 FIJAS

2 SWIVEL WHEELS  
2 FIXED WHEELS

**RCAR104-5**

72,0 kg.

4 GIRATORIAS  
4 SWIVEL WHEELS

**RCAR104**

73,0 kg.

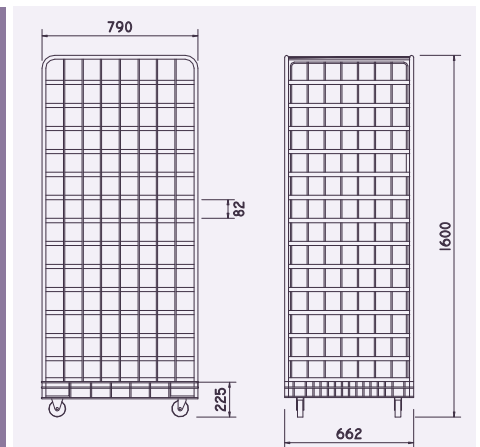



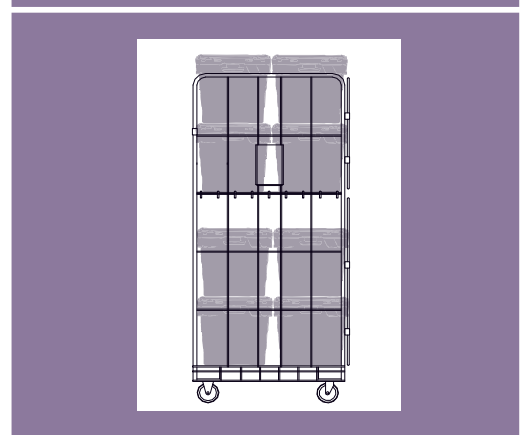
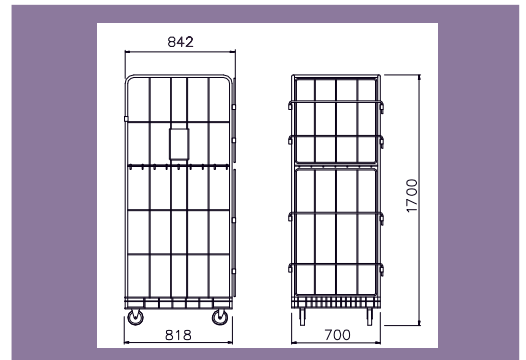
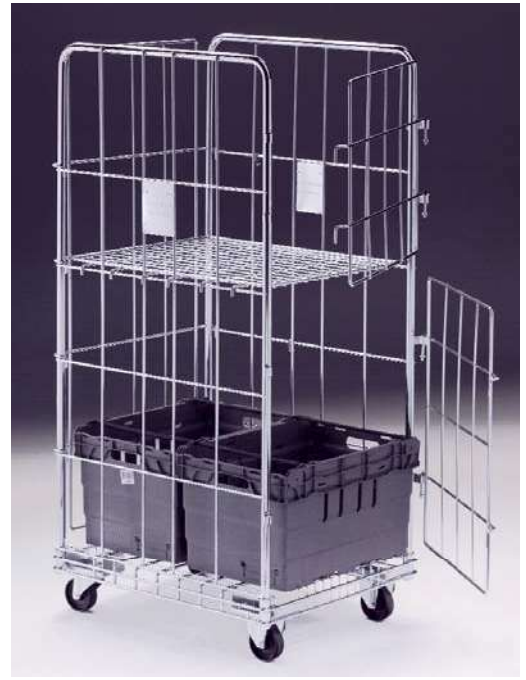

ESPECIALMENTE DISEÑADO PARA EL CONCEPTO DE ALMACENES "DRIVE".

SPECIALLY DESIGNED FOR "DRIVE" WAREHOUSE CONCEPT.

**CODIFICACION BASICA ROLL-DRIVE**

**ROLL-DRIVE CODE**



**800  
x  
700**

2 GIRATORIAS  
2 FIJAS  
2 SWIVEL WHEELS  
2 FIXED WHEELS

4 GIRATORIAS  
4 SWIVEL WHEELS

**RD87/116-7**  
42,6 kg.

**RD87/118-9**  
43,05kg.

**RD87/102-3**  
43,0 kg.

**RD87/104-5**  
43,6 kg.

**RD87/116**  
42,6 kg.

**RD87/118**  
43,05kg.

**RD87/102**  
43,0 kg.

**RD87/104**  
43,6 kg.





**CODIFICACION BASICA ROLL-TAINER**

**ROLL-TAINER CODE**



2 GIRATORIAS  
2 FIJAS  
2 SWIVEL WHEELS  
2 FIXED WHEELS

**MR102-3**  
24,0 kg.

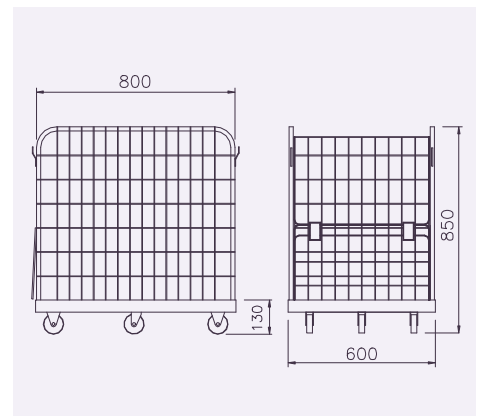

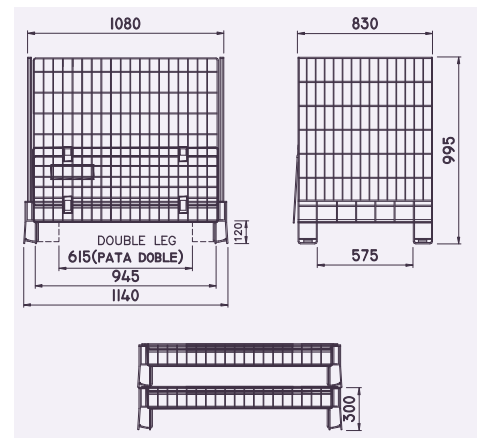
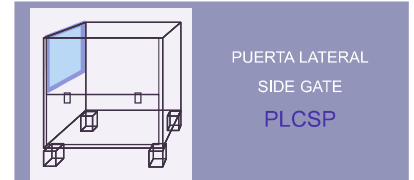
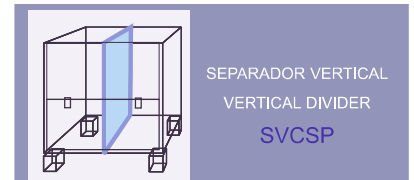

**CODIFICACION BASICA DE CONTENEDORES**

**CONTAINER CODE**

PESO EN VACIO: **49 KG.**  
CARGA ADMISIBLE: **1000KG.**  
CAPACIDAD: **750 LITROS**  
  
WEIGHT WHEN EMPTY: **49 KG.**  
ADMISSIBLE LOAD: **1000 KG.**  
CAPACITY: **750 LITERS**



**SIN RUEDAS**  
**WITHOUT WHEELS**

- 2 GIRATORIAS  
2 FIJAS
- 2 SWIVEL WHEELS  
2 FIXED WHEELS

---

- 4 GIRATORIAS
- 4 SWIVEL WHEELS

**CSPPS104-5**

**CSPPS104**

**CSPPS**

**PATA SENCILLA**  
**SINGLE LEG**

- 2 GIRATORIAS  
2 FIJAS
- 2 SWIVEL WHEELS  
2 FIXED WHEELS

---

- 4 GIRATORIAS
- 4 SWIVEL WHEELS

**CSPSP102-3**

**CSPSP102**

**CSPSP104-5**

**CSPSP104**

**SIN PATA**  
**WITHOUT LEG**



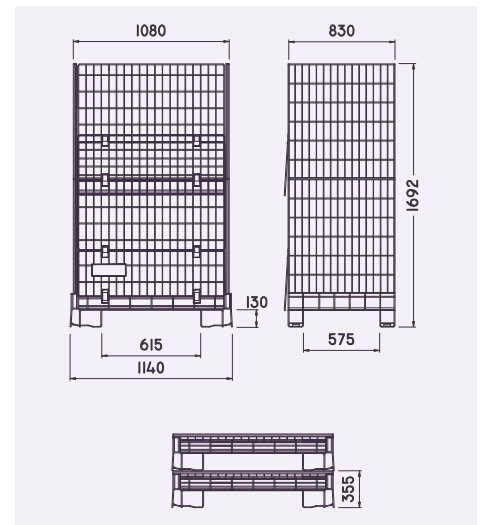
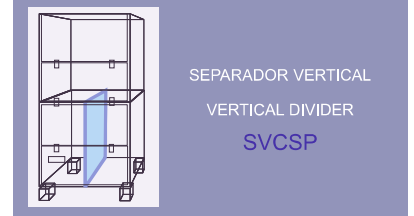
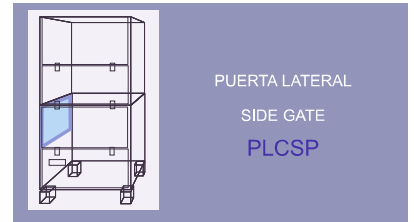

**CODIFICACION BASICA DE CONTENEDORES**

**CONTAINER CODE**

PESO EN VACIO: **65 KG.**  
CARGA ADMISIBLE: **1000 KG.**  
CAPACIDAD: **1400 LITROS**

WEIGHT WHEN EMPTY: **65 KG.**  
ADMISSIBLE LOAD: **1000 KG.**  
CAPACITY: **1400 LITERS**

SIN RUEDAS  
WITHOUT  
WHEELS

**CSPDA**



**CSPDA104-5**

**CSPDA104**

2 GIRATORIAS  
2 FIJAS  
2 SWIVEL WHEELS  
2 FIXED WHEELS

4 GIRATORIAS  
4 SWIVEL WHEELS



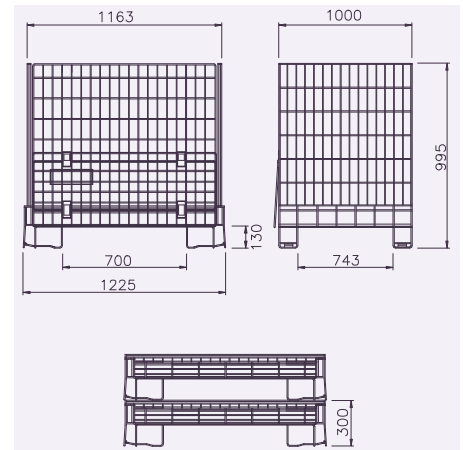
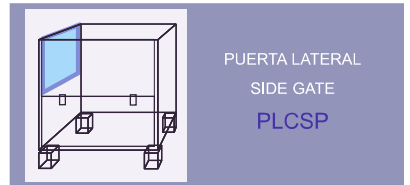
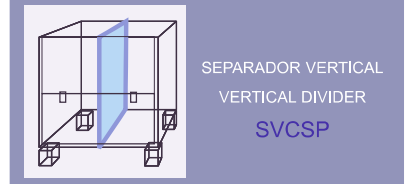

**CODIFICACION BASICA DE CONTENEDORES**

**CONTAINER CODE**

|  |                                      |   |  |
|--|--------------------------------------|---|--|
| <p>PESO EN VACIO: <b>56 KG.</b><br/>CARGA ADMISIBLE: <b>1000 KG.</b><br/>CAPACIDAD: <b>1000 LITROS</b></p> <p>WEIGHT WHEN EMPTY: <b>56 KG.</b><br/>ADMISSIBLE LOAD: <b>1000 KG.</b><br/>CAPACITY: <b>1000 LITERS</b></p> | <p>SIN RUEDAS<br/>WITHOUT WHEELS</p> |  <b>104</b> 125 Ø<br> <b>105</b> 125 Ø | <p>2 GIRATORIAS<br/>2 FIJAS</p>                                    |
|  | <p>PATA DOBLE<br/>WITHOUT LEG</p>    |   | <p><b>CGSPS104-5</b></p> <p>2 SWIVEL WHEELS<br/>2 FIXED WHEELS</p> |
|  | <p><b>CGSPPD</b></p>                 | <p><b>CGSPS104</b></p>  | <p>4 GIRATORIAS<br/>4 SWIVEL WHEELS</p>                            |



PALET NO INCLUIDO  
PALLET NOT INCLUDED

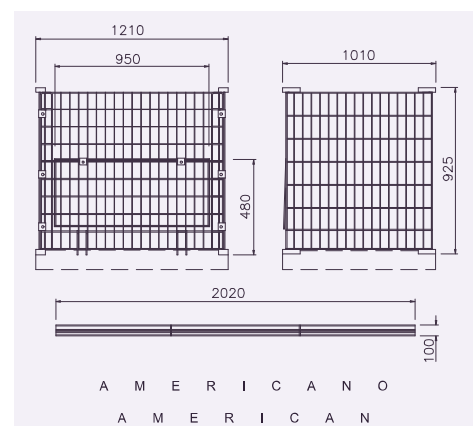
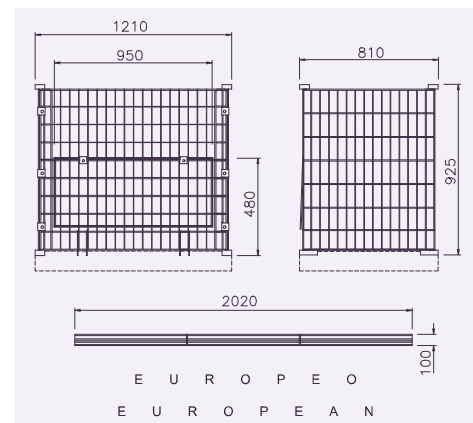
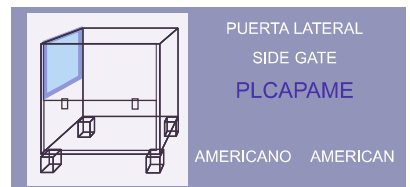
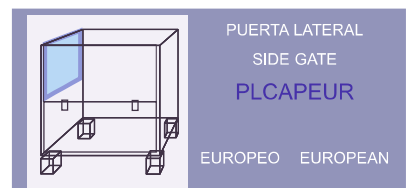
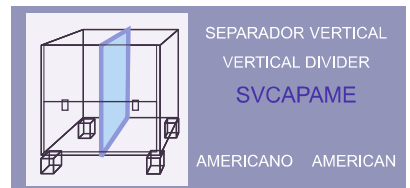
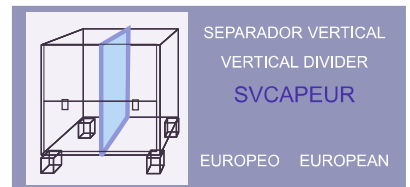

CODIFICACION BASICA DE CONTENEDOR

CONTAINER CODE

PESO EN VACIO: **32 KG.**  
CAPACIDAD: **850 LITROS**

WEIGHT WHEN EMPTY: **32 KG.**  
CAPACITY: **850 LITERS**

E U R O P E O  
E U R O P E A N

**CAPEUR**

PESO EN VACIO: **35 KG.**  
CAPACIDAD: **1000 LITROS**

WEIGHT WHEN EMPTY: **35 KG.**  
CAPACITY: **1000 LITERS**

A M E R I C A N O  
A M E R I C A N

**CAPAME**



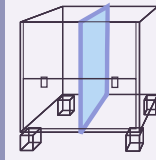

SEPARADOR VERTICAL -M.METRO-  
VERTICAL DIVIDER  
SVMODM

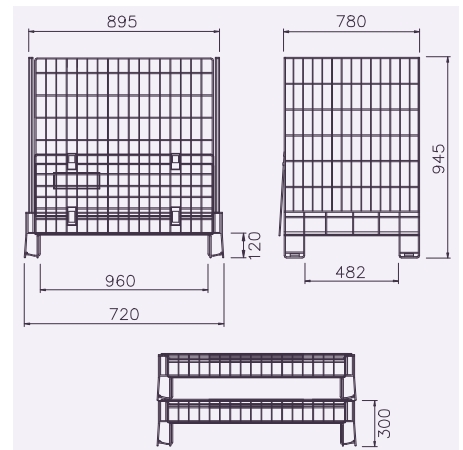

CODIFICACION BASICA DE CONTENEDORES

CONTAINER CODE

|  |  |  |   |
|--|--|--|---|
| <p>PESO EN VACIO: <b>36 KG.</b><br/>CARGA ADMISIBLE: <b>750 KG.</b><br/>CAPACIDAD: <b>570 LITROS</b></p> <p>WEIGHT WHEN EMPTY: <b>36 KG.</b><br/>ADMISSIBLE LOAD: <b>750 KG.</b><br/>CAPACITY: <b>570 LITERS</b></p> | <p>SIN RUEDAS<br/>WITHOUT WHEELS</p> <p><b>CMODM</b></p> |  <p><b>104</b>    125 Ø</p>  <p><b>105</b>    125 Ø</p> <p><b>CMODM104-5</b></p> <p><b>CMODM104</b></p> | <p>2 GIRATORIAS<br/>2 FIJAS</p> <p>2 SWIVEL WHEELS<br/>2 FIXED WHEELS</p> <p>4 GIRATORIAS<br/>4 SWIVEL WHEELS</p> |
|--|--|--|---|



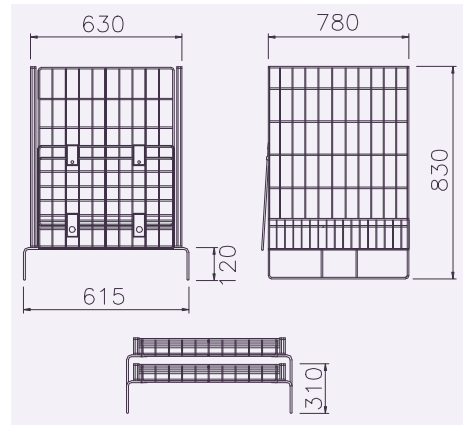

CODIFICACION BASICA DE CONTENEDORES

CONTAINER CODE

PESO EN VACIO: **23 KG.**  
 CARGA ADMISIBLE: **450 KG.**  
 CAPACIDAD: **350 LITROS**

WEIGHT WHEN EMPTY: **23 KG.**  
 ADMISSIBLE LOAD: **450 KG.**  
 CAPACITY: **350 LITERS**

SIN RUEDAS  
 WITHOUT WHEELS

**CMMOD**



**CMMOD102-3**

2 GIRATORIAS  
 2 FIJAS  
 2 SWIVEL WHEELS  
 2 FIXED WHEELS

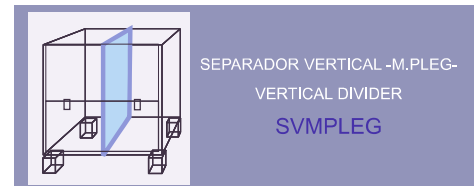
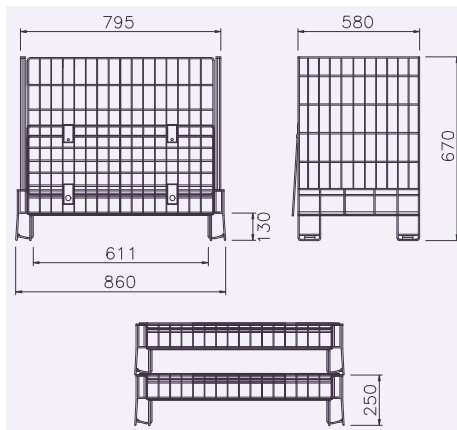

CODIFICACION BASICA DE CONTENEDORES

CONTAINER CODE

PESO EN VACIO: **18 KG.**  
 CARGA ADMISIBLE: **300 KG.**  
 CAPACIDAD: **240 LITROS**

WEIGHT WHEN EMPTY: **18 KG.**  
 ADMISSIBLE LOAD: **300 KG.**  
 CAPACITY: **240 LITERS**

SIN RUEDAS  
 WITHOUT WHEELS

**CMPLEG**



**CMPLEG02**

4 GIRATORIAS  
 4 SWIVEL WHEELS